



Zzipco Elevator Shackle Assembly

ZZWNS Elevator Shackles have been approved by MEA (City of New York, Building Department), the State of California, and TSSA, Canada.

All standard wedge shackles are painted with a black body color coded to match each wedge color for the highest safety standards.

Special wedge shackle assemblies are offered for governor rope applications.

All shackles come with wedge, two rope retaining clips, cotter pin, washer, and two (2) nuts as standard.

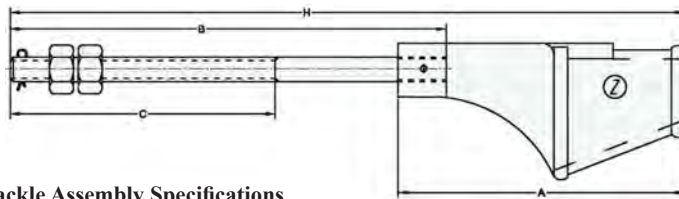

Wedge Shackle Assembly Specifications

Part Number	Size	A	B	C	Nut Size	H
ZZWNS8	1/4"-5/16" (6-8 mm)	5"	12", 18", 24"	9.05"	M12	17", 23", 29"
ZZWNS10	3/8" (10 mm)	6"	12", 18", 24"	9.05"	M12	17", 23", 29"
ZZWNS13	7/16"-1/2" (11-13 mm)	7.5"	12", 18", 24", 30", 36", 42"	9.05"	M20	18", 24", 30", 36", 42", 48"
ZZWNS16	9/16"-5/8" (14-16 mm)	7.5"	12", 18", 24", 30", 36", 42"	9.05"	M20	18", 24", 30", 36", 42", 48"
ZZWNS19	11/16"-3/4" (17.5-19 mm)	9"	12", 18", 24", 30", 36", 42"	9.05"	M24	19.5", 25.5", 31.5", 37.5", 43.5", 49.5"

Standard Rod Lengths are listed above. Additional rod Lengths are available.

Governor Wedge Shackle Specifications

Part Number	Size
ZZWG10	3/8" (10 mm)
ZZWG13	7/16"-1/2" (11-13 mm)
ZZWG16	9/16"-5/8" (14-16 mm)

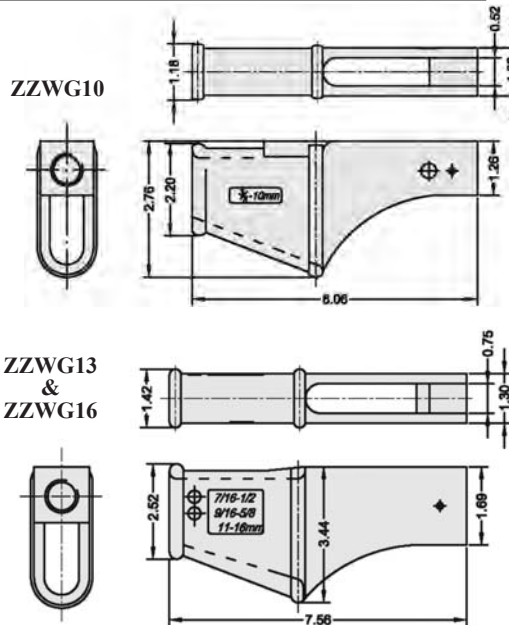

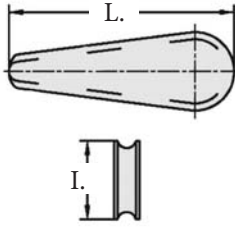

Wedge Insert Specifications

Part Number	Size	L	I	Color
ZZWW8	1/4"-5/16" (6-8 mm)	3.25"	0.9"	White
ZZWW10	3/8" (10 mm)	3.75"	1.3"	Red
ZZWW13	7/16"-1/2" (11-13 mm)	4"	1.6"	Blue
ZZWW16	9/16"-5/8" (14-16 mm)	4.7"	1.3"	Yellow
ZZWW19	11/16"-3/4" (17.5-19 mm)	5.5"	1.57"	Green



ELEVATOR PRODUCTS

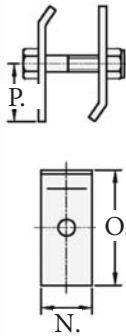

Retaining Clip Specifications

Part Number	Size	N	O	P	Nut Size	Bolt Size
ZZWRC810	1/4"-3/8" (6-10 mm)	1"	1.58"	0.7"	M6	M6x30mm
ZZWRC1316	7/16"-5/8" (11-16 mm)	1"	1.84"	0.94"	M6	M6x35mm
ZZWRC19	11/16"-3/4" (17.5-19 mm)	1"	2.14"	1.06"	M6	M6x40mm

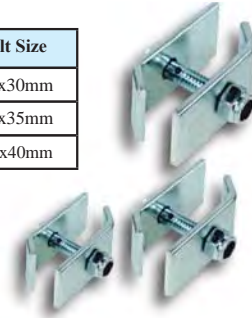

Spring Isolation Bushing Assembly

Spring Isolation Bushing Assemblies assist in providing equal tensioning of all wire rope. In addition, metal parts are isolated to provide noiseless operation between the sockets, spring, and hitch plate.

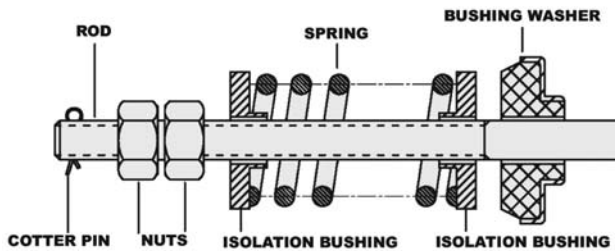

Spring Isolation Bushing Assembly

Part Number	Size
ZZWS10	3/8" (10 mm)
ZZWS13	7/16"-1/2" (11-13 mm)
ZZWS16	9/16"-5/8" (14-16 mm)
ZZWS19	11/16"-3/4" (17.5-19 mm)